

# 2-Fiber PHORTE™

## KEY FEATURES

- ❖ Fully supports CoaXPress standard with high speed downlink and low speed uplink
- ❖ Supports all high speed bit rates – 1.25G, 2.5G, 3.125G, 5G and 6.25Gb/s
- ❖ Supports PoCXP function to supply power to camera and receive power from grabber
- ❖ Transparent operation – plug and play with no configuration required
- ❖ Extends link distance up to 60km
- ❖ Standard DIN 1.0/2.3 connector
- ❖ Available with extended operating temperature
- ❖ Accepts wide range of DC input 10V~24V DC
- ❖ Power connector with secure locking mechanism
- ❖ LED indicators for operating status
- ❖ Require only 1 standard LC duplex fiber connector

## TARGET APPLICATIONS

- ❖ Solar panel or glass panel inspection
- ❖ Semiconductor wafer inspection
- ❖ High speed printing inspection
- ❖ High precision surface inspection (e.g. airplane surface or automobile painting)
- ❖ Automated product inspection (e.g. food, drinking or pharmaceutical products)
- ❖ High resolution and real-time analysis for science, sports, automobile tests, and 3-D animation.
- ❖ High precision security surveillance (e.g. border control, airport)
- ❖ Traffic surveillance/control and vehicle license plate reading/recording (e.g. toll booth)
- ❖ Cameras placed in harsh environment (e.g. nuclear plant, steel mill or undersea monitoring)Other machine vision applications

**PHRONTIER™**  
TECHNOLOGIES

## PHORTE™ 4ch CoaXPress Fiber Extender with 2 fibers

PHT4D-xx



Phrontier Technologies, LLC  
[www.phrontier-tech.com](http://www.phrontier-tech.com)  
sales@phrontier-tech.com  
Toll Free: 1-866-389-2829  
Fax: 1-801-998-1855

## TYPICAL SET UP DIAGRAM

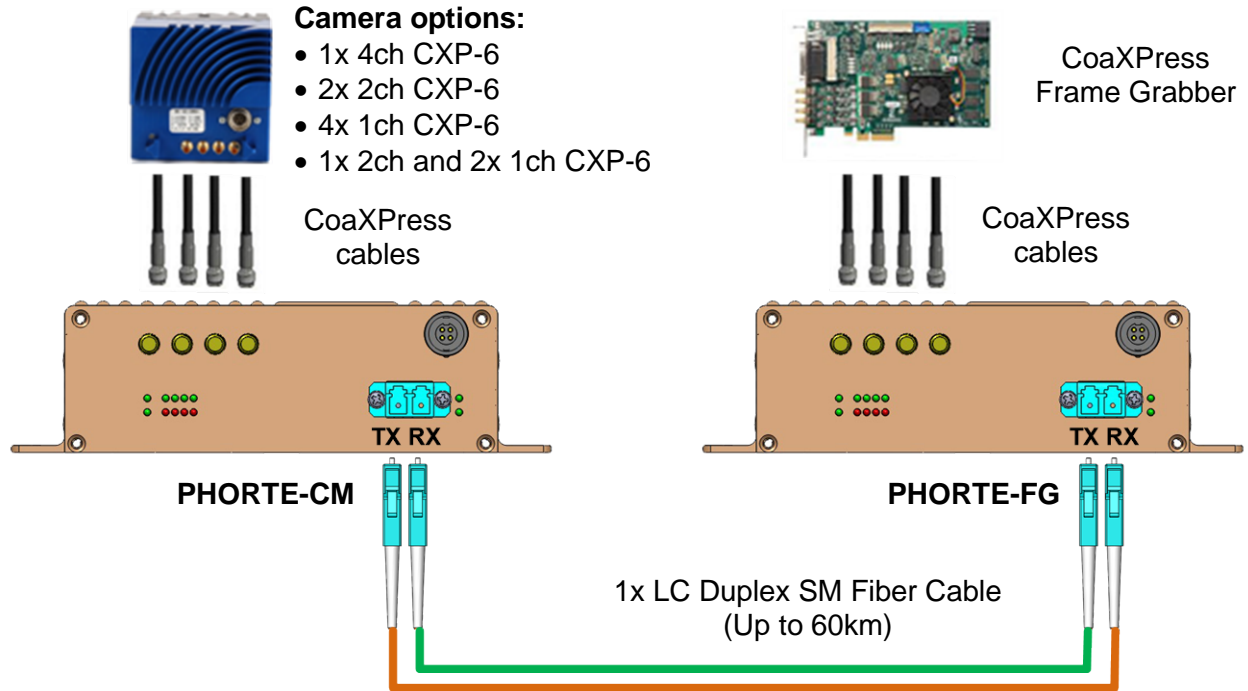

## PHT4D TECHNICAL SPECIFICATIONS

### General Specification

Storage Temperature		-40 ~ 85 °C
Operating Temperature Without PoCXP	Ambient	0 ~ 55 °C
	Case	0 ~ 65 °C
Extended Operating Temperature* <sup>1</sup> Without PoCXP	Ambient	-20 ~ 60 °C
	Case	-20 ~ 70 °C
Operating Humidity		20 ~ 80% (non-condensing)
Input Voltage		DC 10 ~ 24 V
Typical Power Consumption Per Module* <sup>2</sup>		5.8W for CM, 5W for FG
Power Connector on Module		Binder 09-0982-00-04
Approx. Weight (each module)		560 gram

\*<sup>1</sup> Not available for the PHT4D-20

\*<sup>2</sup> Measurements are done with PHT4D-10 @ 25C

### CoaXPress Interface

Downlink Data Rate	CXP-1, CXP-2, CXP-3, CXP-5, CXP-6
Uplink Data Rate	20.83 Mb/s
Connector	DIN1.0/2.3
PoCXP Output Voltage	24 V
PoCXP Supply Power	17W/Ch

## Optical Interface

	PHT4D-10	PHT4D-20	PHT4D-60
Operating Wavelength <sup>*3</sup>	1270/1290/1310/1330	1270/1290/1310/1330	1310/1490/1510/1530/ 1550
Optical Tx Output <sup>*4</sup>	-5 ~ 0 dBm	-1 ~ +4 dBm	0 ~ +4 dBm
Min Optical Rx Input <sup>*4</sup>	-15 dBm	-15 dBm	-20 dBm
Max Optical Rx Input <sup>*5</sup>	+0.5 dBm	+0.5 dBm	-8 dBm
Estimated Link Distance <sup>*6</sup>	10km (6.2 miles)	20km (12.4 miles)	60 km (37.3 miles)
Connector Type	LC duplex		
Fiber Counts	2		
Fiber Type	9/125 um SM		

<sup>\*3</sup> Other wavelengths are available for customization

<sup>\*4</sup> Average optical power measured at the corresponding wavelength.

<sup>\*5</sup> Exceeding this value would overload the optical receiver and may damage the receiver circuitry

<sup>\*6</sup> The link distance is estimated at 1310 and 1550nm under direct connection. Extra optical losses in the system will reduce the link distance.

## PHT4D-xx MECHANICAL INFORMATION (mm)

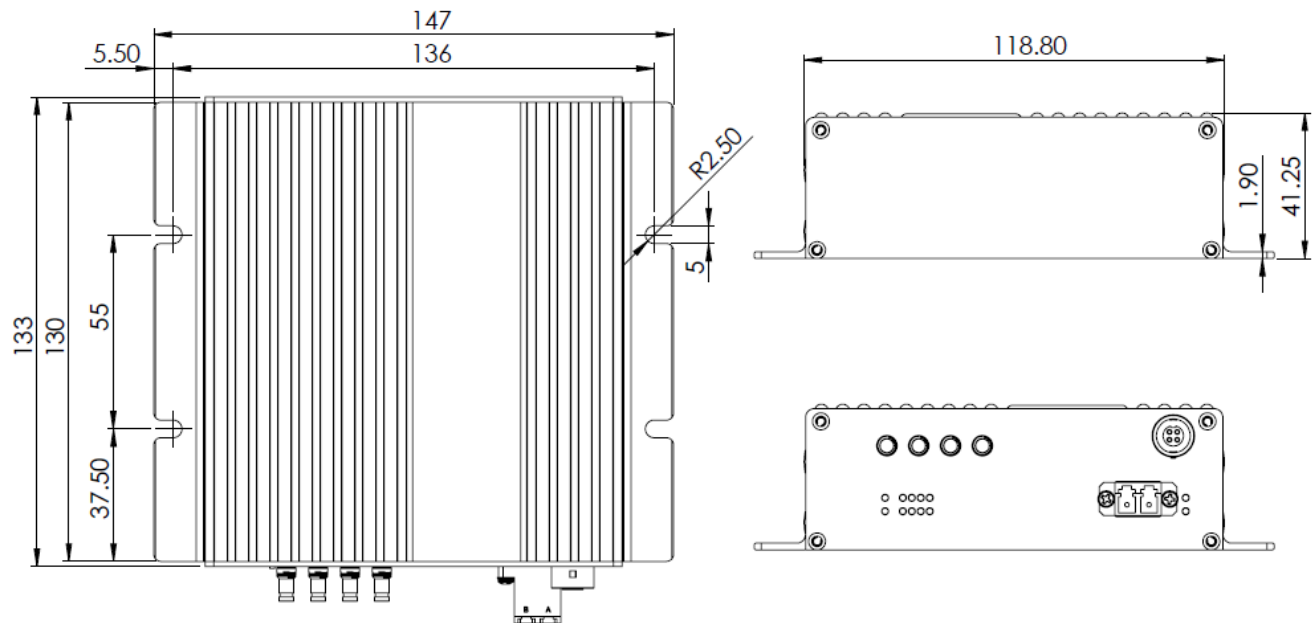

## ORDERING INFORMATION

### PHT4D Standard models

Model #	Fiber Type & Estimated Link Distance *		Fiber count	Items Provided
PHT4D-10	SM	10 km (6.2 miles)	2	1x PHORTE-CM 1x PHORTE-FG
PHT4D-20	SM	20 km (12.4 miles)	2	1x 24W, DC 24V international wall mount AC/DC adapter (fiber cable not included)
PHT4D-60	SM	60 km (37.3 miles)	2	

\* Distance depending on fiber type and system design. Extra optical losses in the system will reduce the transmission distance. Longer link distance is available upon request.

### PHT4D Temperature option

Model #	Description
PHT4D-10-T	Extended operating case temperature range -20 ~ 70C
PHT4D-60-T	Extended operating case temperature range -20 ~ 70C

### PHT4D PoCXP disable option

Model #	Options
Standard # -D	Disable PoCXP function on the CM module (ex: PHT4D-10-T-D)

### Accessory

Part #	Description
618-GE24I24-BD	24W, DC 24V international wall mount AC/DC adapter with Binder plug
618-VES90-BD	90W, DC 24V international wall mount AC/DC adapter with Binder plug
LC-LC-S-D-xxxM	LC to LC duplex 9/125 SM fiber. xxx = desired length in meters.



Phrontier Technologies, LLC  
[www.phrontier-tech.com](http://www.phrontier-tech.com)  
[sales@phrontier-tech.com](mailto:sales@phrontier-tech.com)  
 Toll Free: 1-866-389-2829  
 Fax: 1-801-998-1855