

## PRODUCT BRIEF

The PHANTA product family is designed for Camera Link cameras where the captured images need to be distributed to more than one frame grabbers. Applications include intensive parallel image processing, image monitoring and real time image analysis. All products support maximum pixel clock rate at 85MHz. Three options are available for user's applications. 1) 1-to-4 splitter for full/medium/base configuration. 2) Two integrated 1-to-4 splitters for base configuration. 3) 1-to-8 splitter for base configuration. A master frame grabber can be designated by user to control and configure the camera. Image data and camera control signals are independently controlled by DIP switches or via COM port of a PC. All image data will be transmitted to all frame grabbers synchronously and identically.

## KEY FEATURES

- ❖ Fully supports Camera Link cameras/framegrabbers up to 85MHz pixel clock for full/medium/base configurations
- ❖ User selectable master frame grabber
- ❖ Independently controlled image data path, control signal path and serial communication path for maximum signal routing flexibility
- ❖ Output ports can be shut off independently when not used to avoid signal glitch to frame grabbers
- ❖ Reconditioned and synchronized output
- ❖ Standard 1U 19" chassis for easy mounting
- ❖ An array of LED indicators summarize operation status
- ❖ Accept wide range 10V~24V DC power supply
- ❖ Alternative input power terminal for custom power supply
- ❖ Optional locking power supply connector
- ❖ Provide optional DC output power for cameras
- ❖ Can be seamlessly used with our PHOX, PHIRE and PHAST fiber extenders for extended distance

**PHRONTIER™**  
TECHNOLOGIES

**PHANTA™**  
**Camera Link**  
**Splitter/Repeater**  
**Full/Medium/Base**

**PHANTA-S1F4**  
**PHANTA-D2B4**  
**PHANTA-S1B8**

PHANTA Front View



PHANTA Back View



**Phrontier Technologies, LLC**

[www.phrontier-tech.com](http://www.phrontier-tech.com)

[info@phrontier-tech.com](mailto:info@phrontier-tech.com)

**Toll Free: 1-866-389-2829**

**Fax: 1-801-998-1855**

## AVAILABLE MODELS

**PHANTA-S1F4** Connect 1 full/medium/base camera to 4 frame grabbers

**PHANTA-D2B4** Connect 2 base cameras to 2 groups of 4 frame grabbers

**PHANTA-S1B8** Connect 1 base camera to 8 frame grabbers

## TECHNICAL SPECIFICATIONS

### General Specification

Operating Temperature	0 ~ 70 °C
Input Voltage	DC 10 ~ 24 V
Supply Current	Typical 0.3A @12V
Typical Power Consumption	3.6W @ 25 °C
AC/DC Power Supply Connector	12V DC, 0.85A with Switchcraft 760BK locking plug

### Camera Link Interface

Pixel Clock	20 to 85MHz
Configuration	Base/Medium/Full
Image Enables	FVAL, LVAL, DVAL, spare
Camera Control	CC1, CC2, CC3, CC4
Communication	SerTC, SerTFG
Connector Type	MDR26 receptacle

## MECHANICAL INFORMATION (mm)

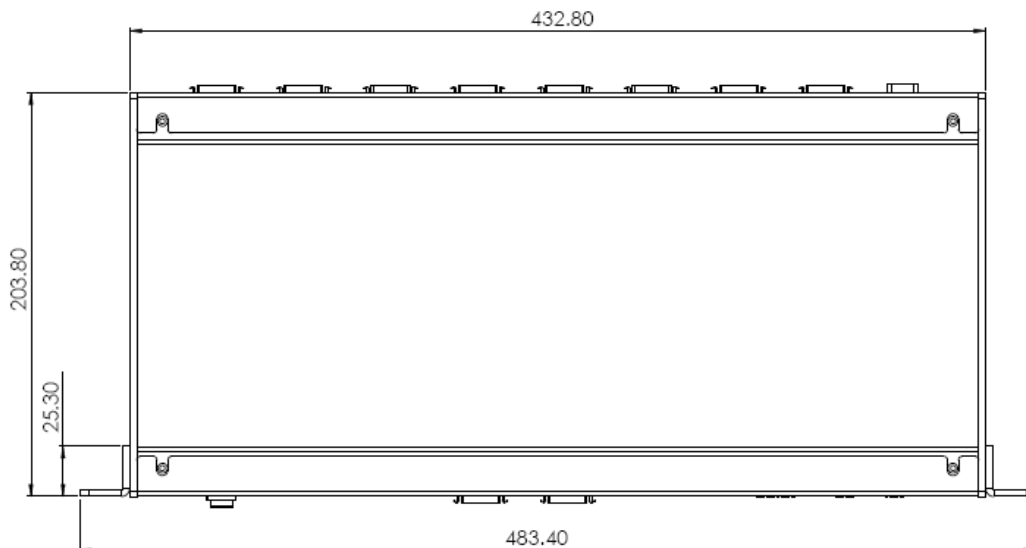

# PHANTA-S1F4/D2B4/S1B8

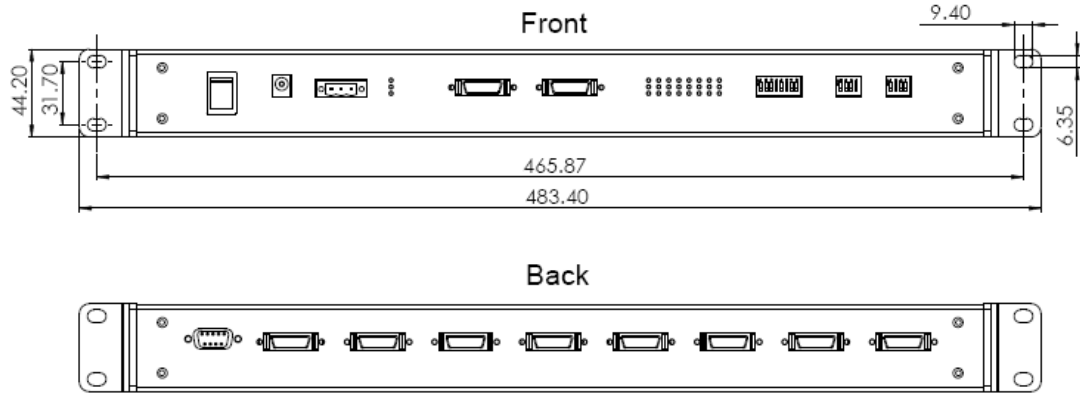

## TYPICAL SETUP

1. PHANTA-S1F4: 1-to-4 distribution for Full/Medium/Base configuration camera and framegrabber

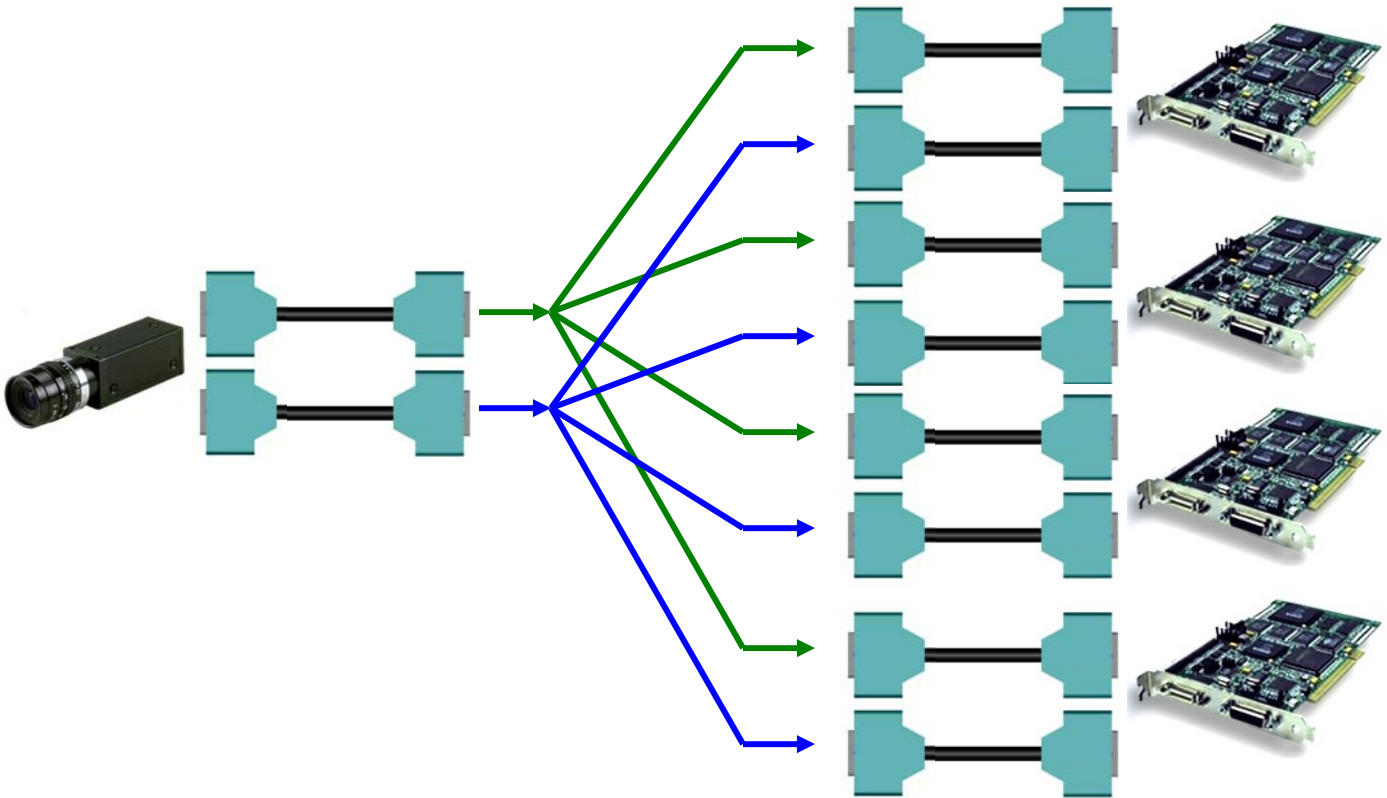

## 2. PHANTA-D2B4: Two 1-to-4 distribution for Base configuration camera and framegrabber

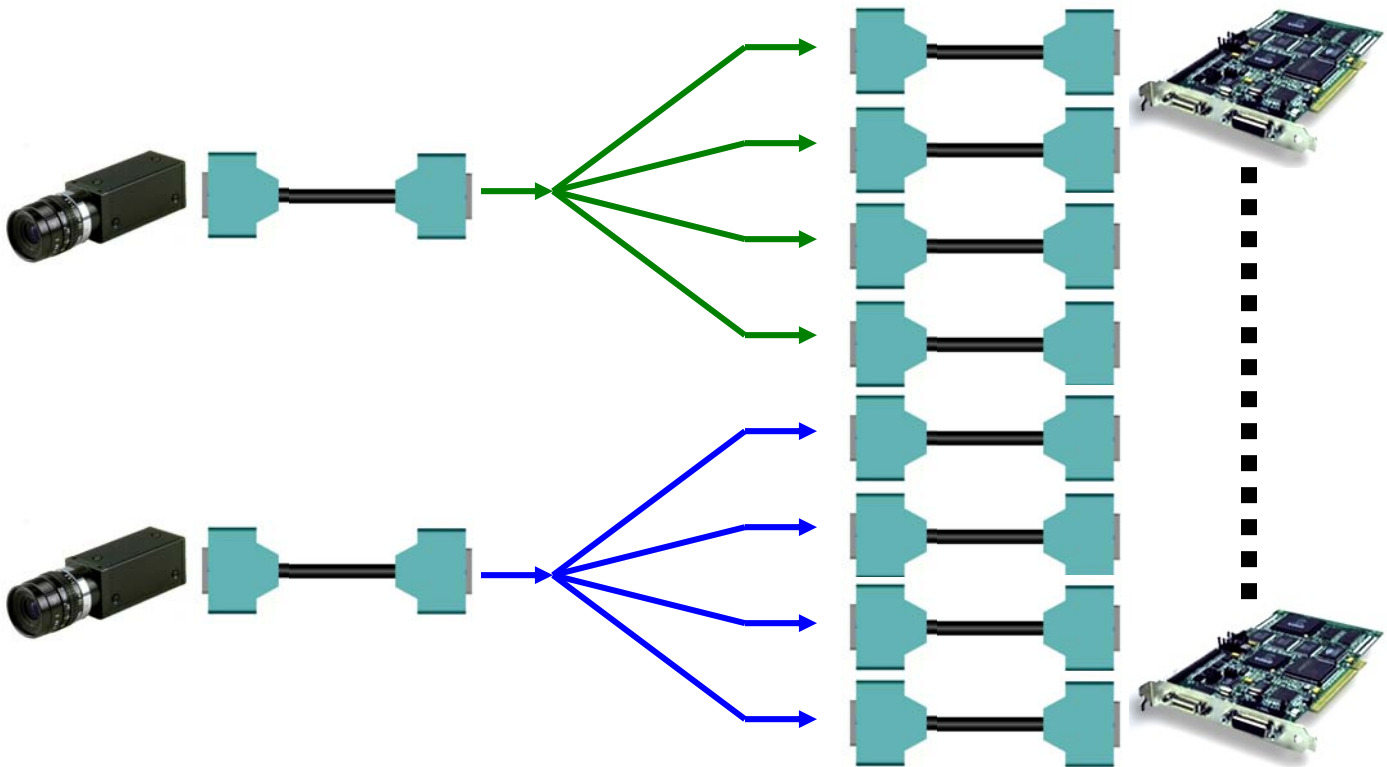

## 3. PHANTA-S1B8: 1-to-8 distribution for Base configuration camera and framegrabber

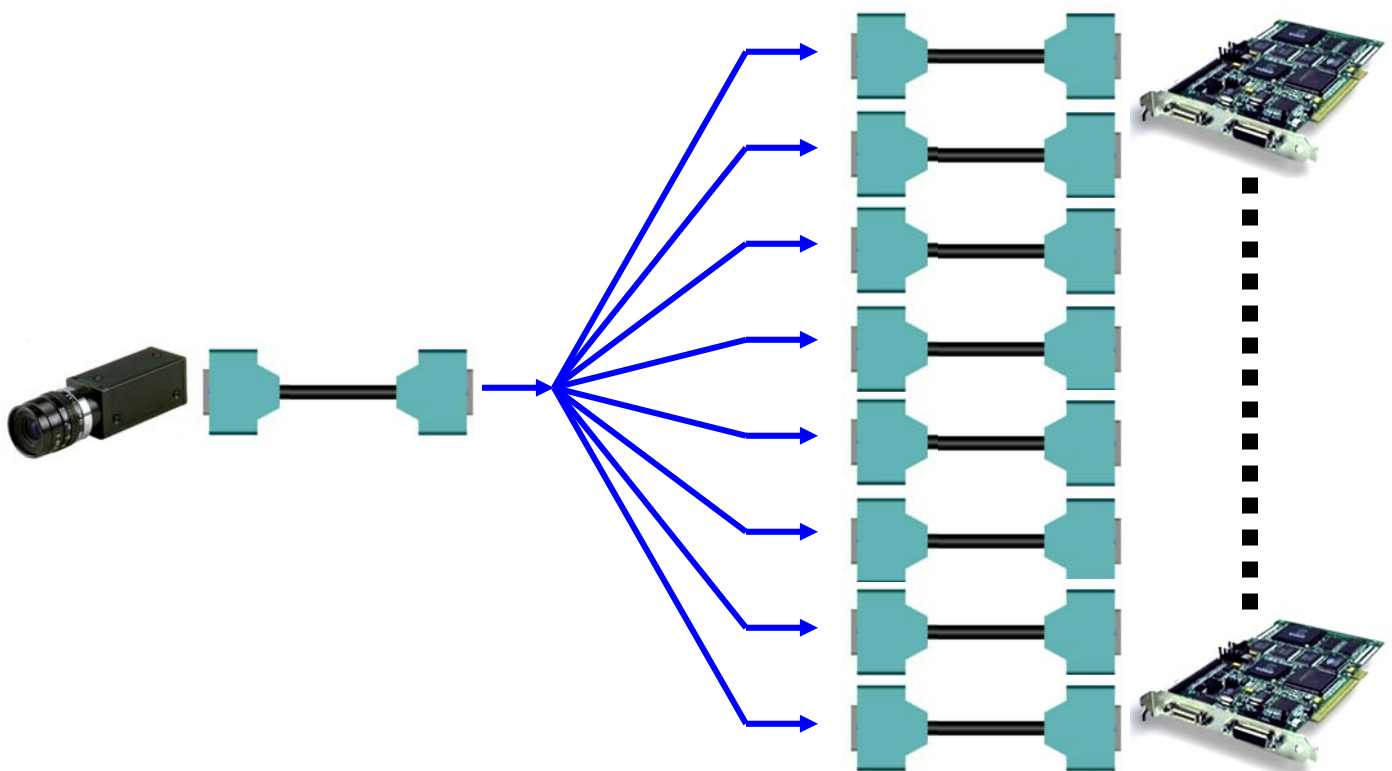

## ORDERING INFORMATION

Model #	Check List
PHANTA-S1F4	1x PHANTA box
PHANTA-D2B4	1x 12V DC output international wall mount AC/DC power adapter
PHANTA-S1B8	1x User manual



[www.phrontier-tech.com](http://www.phrontier-tech.com)

info@phrontier-tech.com

Toll Free: 1-866-389-2829